

XTGL-0301 光學陶瓷投射燈 規格書

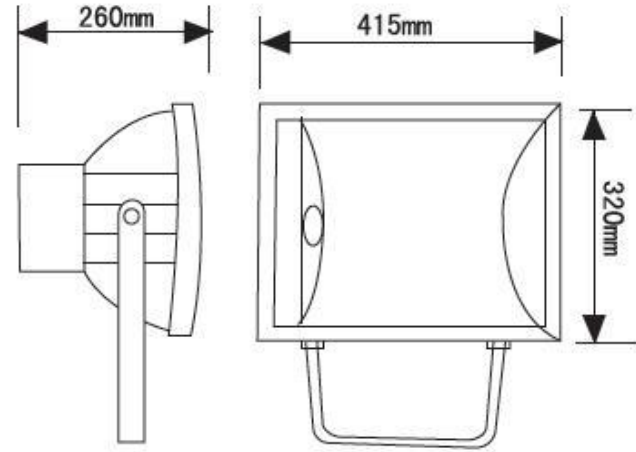

光學反射罩
型號：XTGL-R1



光學反射罩
型號：XTGL-R2



節能型電感安定器三件套
品牌：XTGL

額定瓦數：35W、50W、
70W、100W、150W、
250W

電壓/頻率：220V/ 60Hz(若
有特殊規格要求可先特定,如
馬來西亞為240V/50Hz)



光源
品牌：Philips / OSRAM
型號：CDM-T / HCI-T
瓦數：35W、50W、70W、
100W、150W、250W
色溫：3000k / 4200k
演色性：
3000k ≥ 90
4200k ≥ 90
燈座：G12



IP防護等級：65
燈具壽命：85000小時以上

R1光形圖

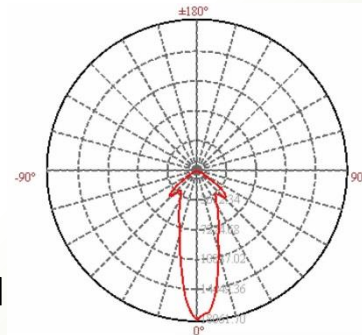

R2光形圖

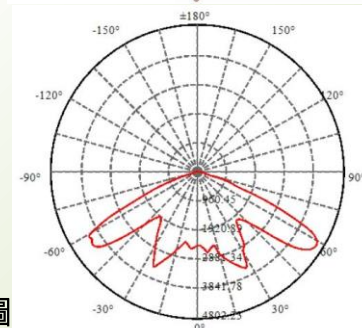

XTGL-0301 XTGL CMH Floodlight Specifications

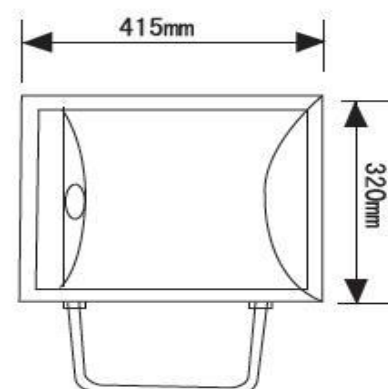
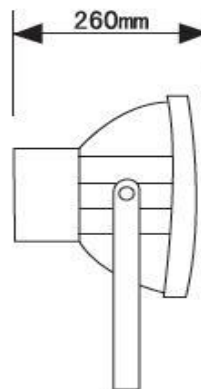

Energy-saving magnetic ballast
 Brand : XTGL
 Watt : 35W 、 50W 、 70W 、 100W 、 150W 、 250W
 Voltage/Frequency : 220V/60Hz
 (Any special specifications can be specific, Ex: Malaysia 240V/50Hz)

IP: IP65
 Life Span: More than 85000 hours

Optical Reflector
 Model : XTGL-R1



Light source:
 Brand : Philips / OSRAM
 Model : CDM-T / HCI-T
 Watt : 35W 、 50W 、 70W 、 100W 、 150W 、 250W
 CCT : 3000k / 4200k
 CRI(Ra) : 3000k \geq 90 4200k \geq 90
 Lamp holder : G12

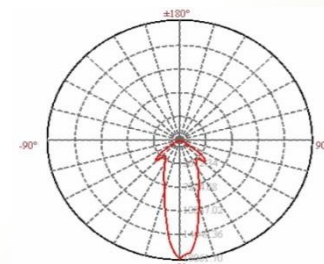

R1 Diagram for luminous intensity distribution

Optical Reflector
 Model : XTGL-R2

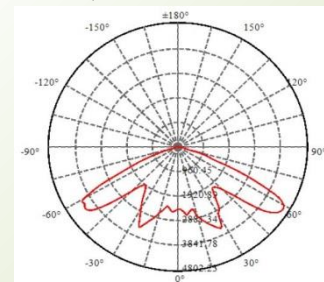

R2 Diagram for luminous intensity distribution